

MK - TSX



FEATURE:

- Heavy duty, reliability and super stability
- Design of metal welded stainless steel
- Easy to installation, good interchangeability
- Constructed of excellent capability in anti erosion, moisture proof
- 5 core high quality orange cable
- Suitable in crane, hopper scales, and other special weighing instruments

Rated Load (t)	A	B	C	D	E
0.1,0.2,0.25,0.3,0.5,0.75	80	70	19	M12	9.5
1,1.5	80	70	25	M12	7
2,3,5	108	95	25	M18x1.5	5.5
7.5,10	178	130	51	M30x2	7
15,20	190	160	60	M39x2	7

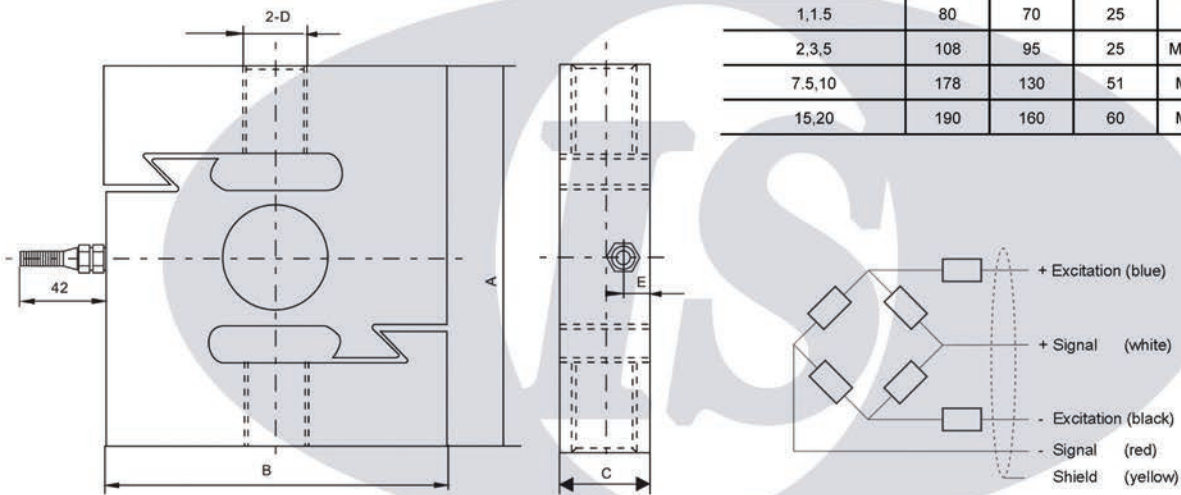

SPECIFICATION

Rated capacities (E _{max})	0.1,0.2,0.25,0.3,0.5,0.75,1,1.5,2,3,5,7.5,10,15,20t	Temperature, compensated	-10°C~+40°C
Rated Output	3.0±0.002mV/V	Temperature, operating	-30°C~+70°C
Total error	±0.05%F.S	Maximum safe overload	120%F.S
Creep error (30 min)	±0.03%F.S	Ultimate overload	250%F.S
Zero balance	±1%F.S	Excitation, recommended	10~12V DC
TC ZERO	±0.03%F.S/10°C	Excitation, maximum	15V DC
TC SPAN	±0.03%F.S/10°C	Protection class	IP68
Input resistance	400±20Ω	Construction	Alloy Steel
Output resistance	352±3Ω	Cable	Length: 6m Diameter: Φ 5mm
Insulation resistance	≥5000MΩ		