



Product Description

The type SB14 is a stainless steel beam type load cell with complete hermetic sealing. It is a perfect fit for use in industrial environments.

Application

- Platform scales, hopper and tank scales

Key Features

- Wide range of capacities from 500 lb to 10 000 lb (227 kg to 4 536 kg)
- Stainless steel construction
- Environmental Protection IP68 with complete hermetic sealing
- Unique blind loading hole
- High input resistance
- Calibration in mV/V/Ω

Options

- Y = 23 000 for C3 and C3 MI6 (for 500 lb to 2 500 lb)
- Stainless steel cable gland

Approvals

- OIML approval to C3 and C3 MI6 (Y = 11 500)
- NTEP approval to 5 000 intervals, Class III (for 500 lb to 5 000 lb)
- ATEX hazardous area approval for Zone 0, 1, 2, 20, 21 and 22
- FM hazardous area approval

Packed Weight

■ Capacity (lb)	500–5 000	10 000
Weight (kg)	1.2	2.44

Available Accessories

- Compatible range of application hardware
- Compatible range of electronics

Specifications

		(E _{max})	klb	0.5 / 1 / 2.5 / 5 / 10	0.5 / 1 / 2.5 / 5
Maximum capacity			kg	227 / 454 / 1 134 / 2268 / 4 536	227 / 454 / 1 134 / 2268
Metric equivalents (1 lb=0.45359 kg)				(GP)	C3 MI 6
Accuracy class according to OIML R60				3 000	3 000
Maximum number of verification intervals (n _{max})				n.a.	E _{max} / 11 500
Minimum load cell verification interval (v _{min})					
Temperature effect on minimum dead load output (TC ₀)		%*RO/10°C		≤ ± 0.0400	≤ ± 0.0122
Temperature effect on sensitivity (TC _{RO})		%*RO/10°C		≤ ± 0.0200	≤ ± 0.0100
Combined error		%*RO		≤ ± 0.0500	≤ ± 0.0200
Non-linearity		%*RO		≤ ± 0.0400	≤ ± 0.0166
Hysteresis		%*RO		≤ ± 0.0400	≤ ± 0.0166
Creep error (30 minutes) / DR		%*RO		≤ ± 0.0600	≤ ± 0.0166
Option					E _{max} / 23 000
Min. load cell verification interval (v _{min opt})				n.a.	
Temp. effect on min. dead load output (TC _{0 opt})		%*RO/10°C		n.a.	≤ ± 0.0061
Rated Output (RO)		mV/V		2 ± 0.1%	
Calibration in mV/V/Ω (A...I classified)		%		≤ ± 0.05 (≤ ± 0.005)	
Zero balance		%*RO		≤ ± 5	
Excitation voltage		V		5...15	
Input resistance (R _{LC})		Ω		1 100 ± 50	
Output resistance (R _{out})		Ω		1 000 ± 2	
Insulation resistance (100 V DC)		MΩ		≥ 5 000	
Safe load limit (E _{lim})		%*E _{max}		200	
Ultimate load		%*E _{max}		300	
Safe side load		%*E _{max}		100	
Compensated temperature range		°C		-10...+40	
Operating temperature range		°C		-40...+80 (ATEX -40...+60)	
Load cell material				stainless steel 17-4 PH (1.4548)	
Sealing				complete hermetic sealing; cable entry sealed by glass to metal header	
Protection according EN 60 529				IP68 (up to 2 m water depth) / IP69K	

The limits for Non-Linearity, Hysteresis, and TC_{RO} are typical values.
The sum of Non-linearity, Hysteresis and TC_{RO} meets the requirements according to OIML R60 with p_{LC}=0.7.

Dimensions (in mm)

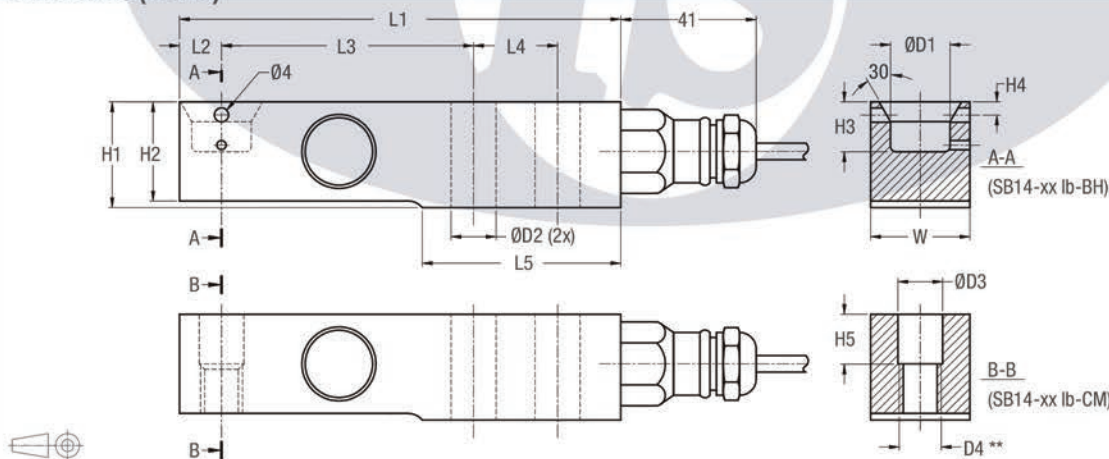

Type	L1	L2	L3	L4	L5	H1	H2	H3	H4	H5	W	D1	D2	D3	D4	Mounting bolts	Torque *
SB14-500 lb/1000 lb	133.4	12.7	76.2	25.4	59.9	31	28.8	15	4	15	30	18	13	13.5	M12	M12 8.8	90 Nm
SB14-2500 lb	133.4	12.7	76.2	25.4	59.9	31	30.5	15	4	15	30	18	13	13.5	M12	M12 8.8	90 Nm
SB14-5000 lb	133.4	12.7	76.2	25.4	59.9	31	30.5	15	4	15	30	18	13	13.5	M12	M12 10.9	120 Nm
SB14-10000 lb	177.8	19.1	95.3	38.1	92.7	43.6	38.1	20.5	8	20.1	43	25	21	21.5	M20	M20 8.8	400 Nm

* Torque values assume oiled threads.

** Unified thread 1/2-20 UNF (500...5000 lb) and 3/4-16 UNF (10000 lb) is available. Type designation SB14-xx-CU.

Wiring

- The load cell is provided with a shielded, 4 conductor cable (AWG 24).
Cable jacket polyurethane
- Cable length: 3 m for SB14-500 lb to 5 000 lb
4.5 m for SB14-10 000 lb
- Cable diameter: 5 mm
- The shield is floating
(On request the shield can be connected to the load cell body)

