

MK - RTN

Part 2

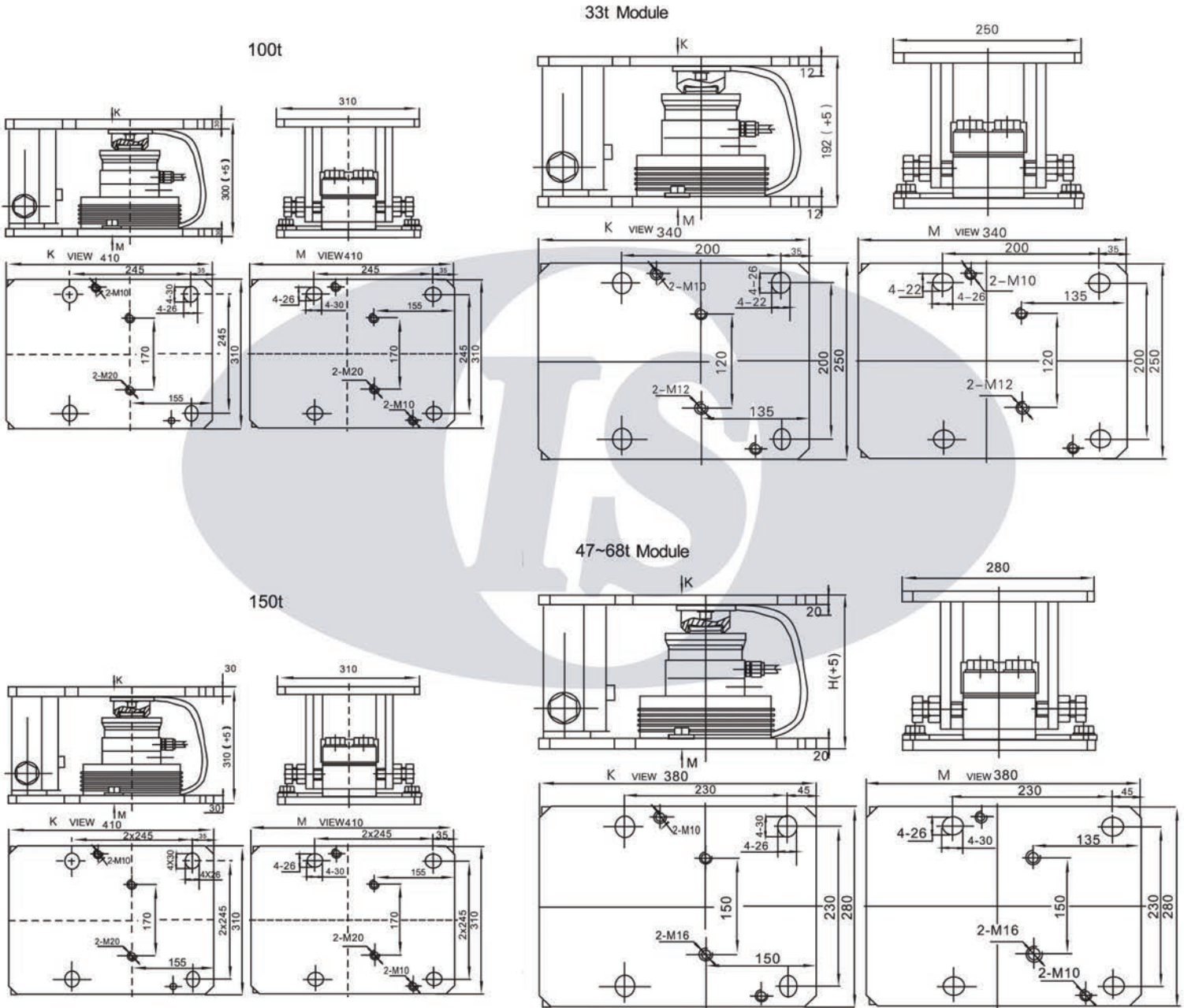

MK - RTN

Part 3

10~150t

Rated Load (t)	A	B	C	H	J	K
10~22	75	30	75	50	7	6.5
33	95	40	95	65	7	10
47	130	60	130	75	7	14
68	130	60	130	85	7	14
100	150	70	150	90	7	16
150	150	70	150	100	7	16

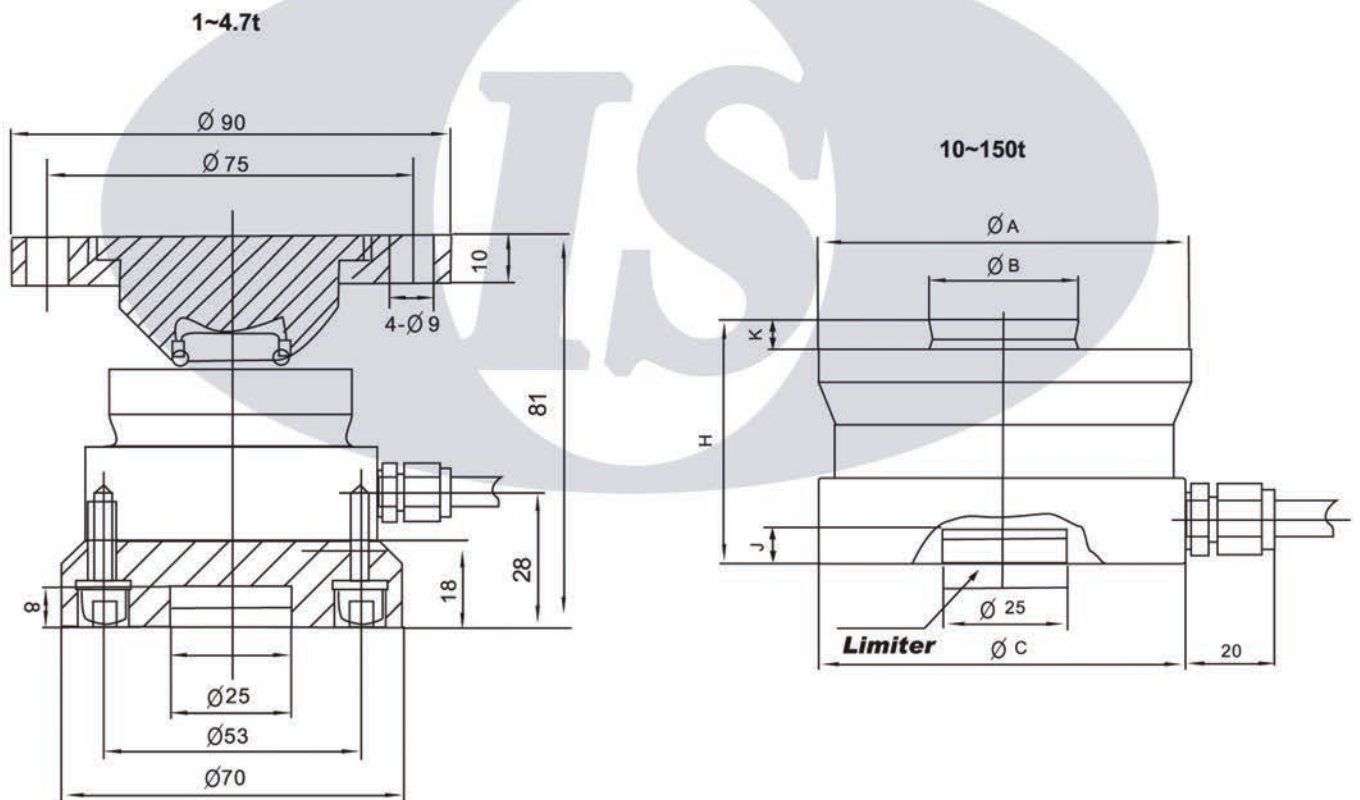

MK - RTN

Part 4

10~100t

Rated Load (t)	A	B	C	D	E	H	K	J	N
10~22	45	75	55	80	100	95	20	11.5	10
33	58	95	68	95	120	120	25	13	12
47	80	130	92	130	170	140	30	17.5	20
68	80	130	92	130	170	150	30	17.5	20
100	100	150	110	150	200	177	40	25	22
150	100	150	110	150	200	187	40	25	22

10~100t

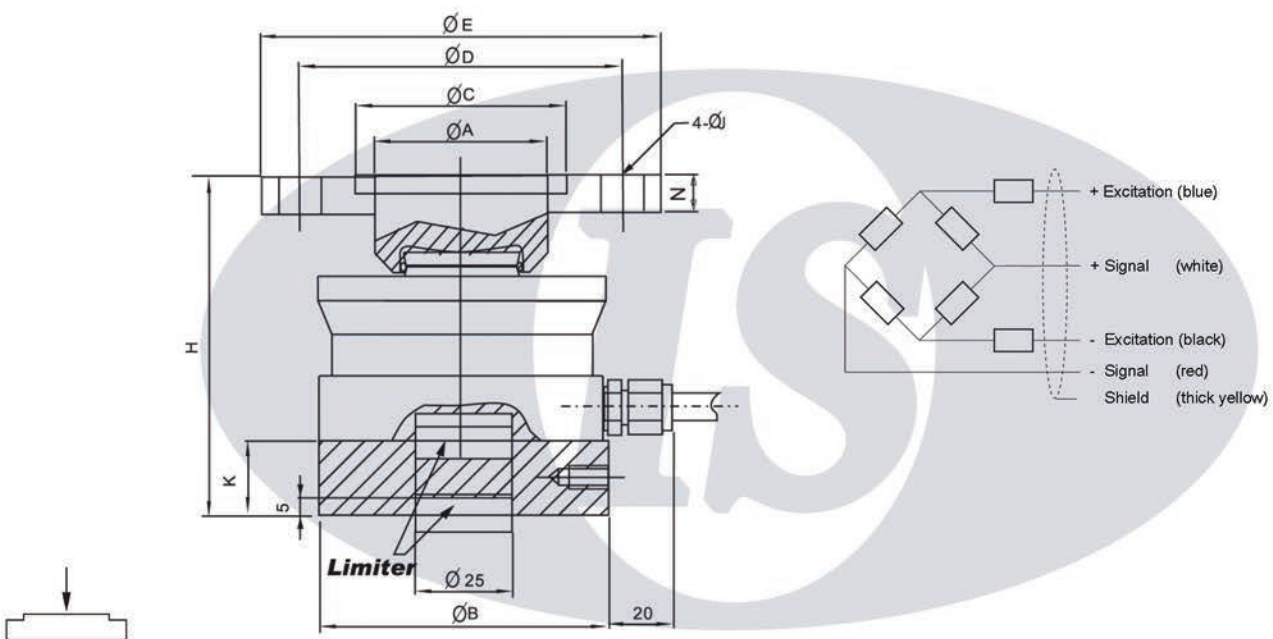

SPECIFICATION

Rated capacities (E _{max})	1,2,2.3,3,3.4,7,10,15,22,33,47,68,100,150t	Temperature, compensated	-10°C~+40°C
Rated Output	2.85±0.015mV/V	Temperature, operating	-30~+70°C
Total error	±0.03, ±0.05, ±0.1%F.S	Maximum safe overload	150%F.S
Creep error (30 min)	±0.03%F.S	Ultimate overload	200%F.S
Zero balance	±1%F.S	Excitation, recommended	10~12V DC
TC ZERO	±0.03%F.S/10°C	Excitation, maximum	15V DC
TC SPAN	±0.03%F.S/10°C	Protection class	IP68
Input resistance	1450±10Ω	Construction	High Quality Alloy Steel
Output resistance	1402±5Ω (L≥15m)	Cable	Length=L:8m(1~4.7t),12m(10~33t),16m(47~150t)
Insulation resistance	≥5000MΩ	Diameter:	Φ 6mm