

MK - LU- D Digital Load Cell Series



FEATURE:

- High precision, reliability and super stability
- Design of stainless steel ball, cup has super functions in self-restoring corner pre-adjustment
- Anti-wallop and anti side force
- Easy to installation good interchangeability
- 5 core high quality orange cable
- Application to truck scale, railway scale hopper scale and other weighing equipment

Rated Load	10-30	40
H (mm)	224.7	230.7

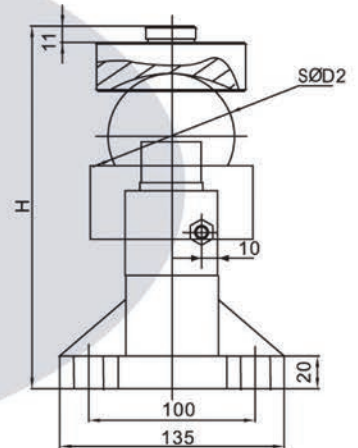
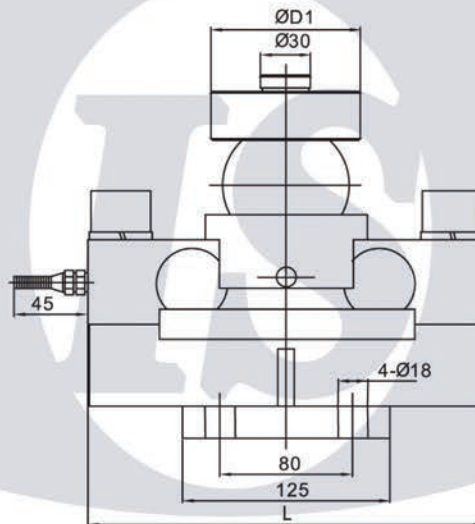
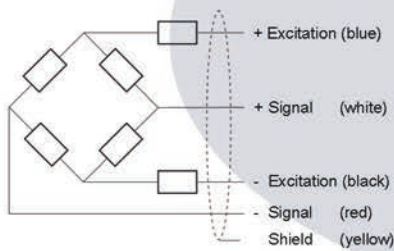

SPECIFICATION

Rated capacities	10,15,20/25,30,40t	Temperature effect sensitivity	±0.02%F.S/10°C
Rated Output	20000, 25000, 30000, 40000	Temperature, operating	-30°C~+70°C
Total error	±0.02%F.S	Maximum safe overload	150%F.S
Creep error (30 min)	±0.02%F.S	Excitation, recommended	9-12V DC
Zero balance	±0.1%F.S	Excitation, maximum	20V DC
Communication Baud Rate	9600 BPS	Protection class	IP 68
Data refresh frequency	50 Hz	Max signal transmission distance	1200m